

SPECIFICATION							
Part	Quantity	Profile	Length, mm	Weight, kg	Weight total, kg	Steel	Note
1045	1	PL25*750	21450	3181.7	3181.7	S355J2	
1046	1	PL25*750	21450	3217.5	3217.5	S355J2	BR
1047	1	PL25*700	20930	2930.2	2930.2	S355J2	BR
1048	2	PL25*700	9788	1368.7	2737.4	S355J2	
1049	2	PL30*500	550	53.1	106.3	S355J2	
1050	2	PL30*258	698	42.5	85.0	S355J2	
1051	2	PL25*700	10214	1430.0	2859.9	S355J2	BR
1052	1	PL30*645	698	93.4	93.4	S355J2	
1053	1	PL100*100	440	34.6	34.6	S355J2	
1054	1	PL25*438	700	61.3	61.3	S355J2	BR
1055	2	PL30*500	550	65.3	130.6	S355J2	
1056	1	PL15*440	500	26.0	26.0	S355J2	
1057	1	PL30*645	698	93.4	93.4	S355J2	
4001	2	PL60*698	750	248.8	497.6	S355J2	
4005	2	PL50*438	500	86.4	172.9	S355J2	
Hg-01	1	PL30*360	440	37.9	37.9	STAINLESS STEEL	
Hg-02	1	PL30*85	440	8.3	8.3	STAINLESS STEEL	
Hg-03	1	PL40*85	440	11.5	11.5	STAINLESS STEEL	
KL-103	1	PL100*1590	2465	2124.3	2124.3	S460M	
WELDS	1%				184.1		
TOTAL					18594.0		
Object:							PRN - KJ-101
Customer:							18594.0 kg
Drawn							
Designed							
Checked							
Approved							
HQ-BEAM							Stage MKD
							Page Pages
							1 1

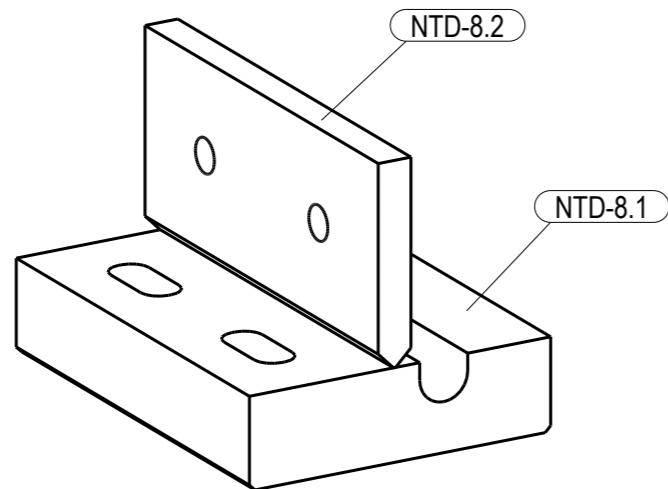

SPECIFICATION							
Part	Quantity	Profile	Length, mm	Weight, kg	Weight total, kg	Steel	Note
NTD-8.1	1	PL80*276	370	61.1	61.1	STAINLESS STEEL	
NTD-8.2	1	PL30*175	370	15.0	15.0	STAINLESS STEEL	
WELDS	1%				0.8		
TOTAL					76.8		
Object:						PRN - Nt8-1	
Customer:						76.8 kg	
Drawn					HINGE BASE		
Designed							
Checked							
Approved							
						Stage	MKD
						Page	Pages
						1	1

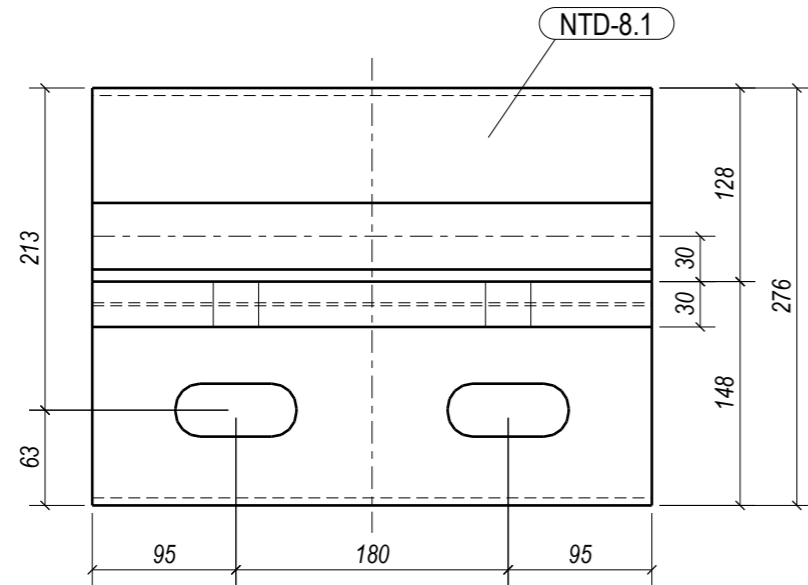
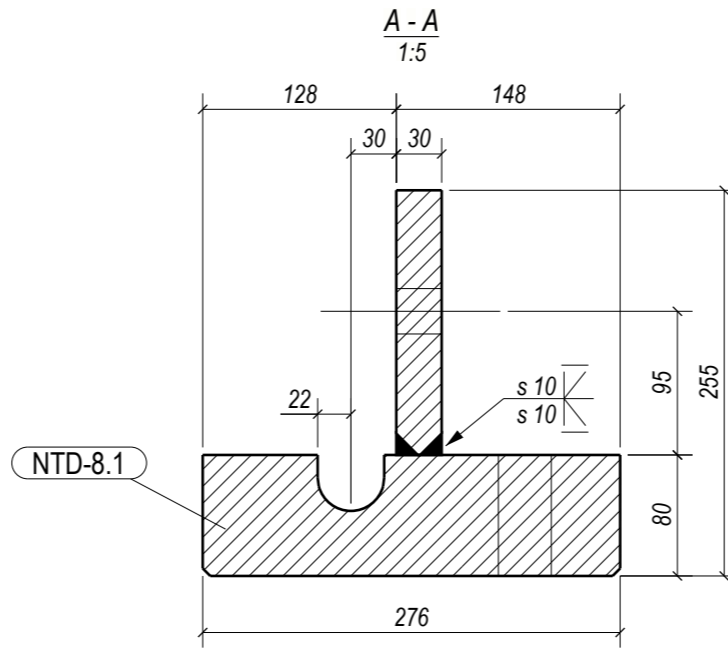
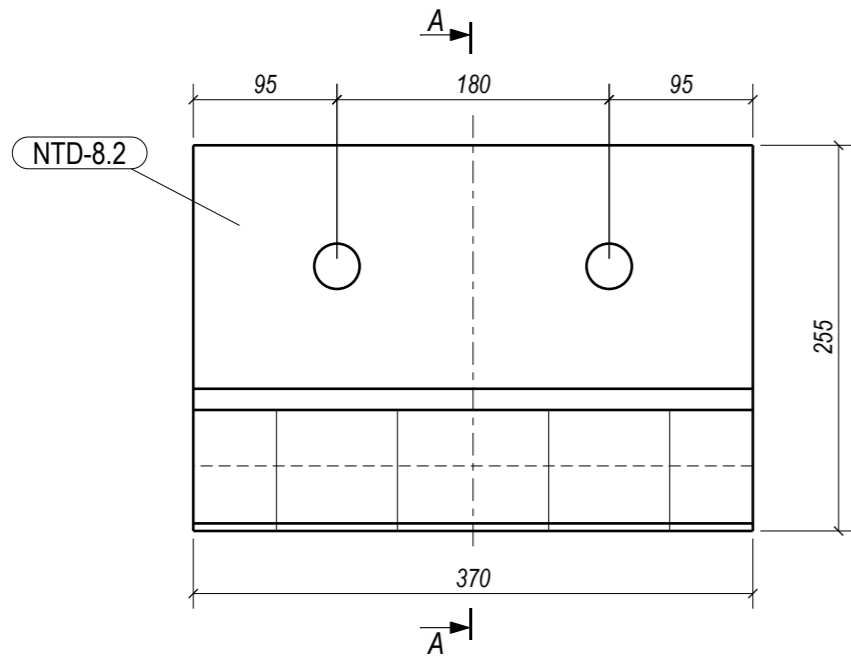
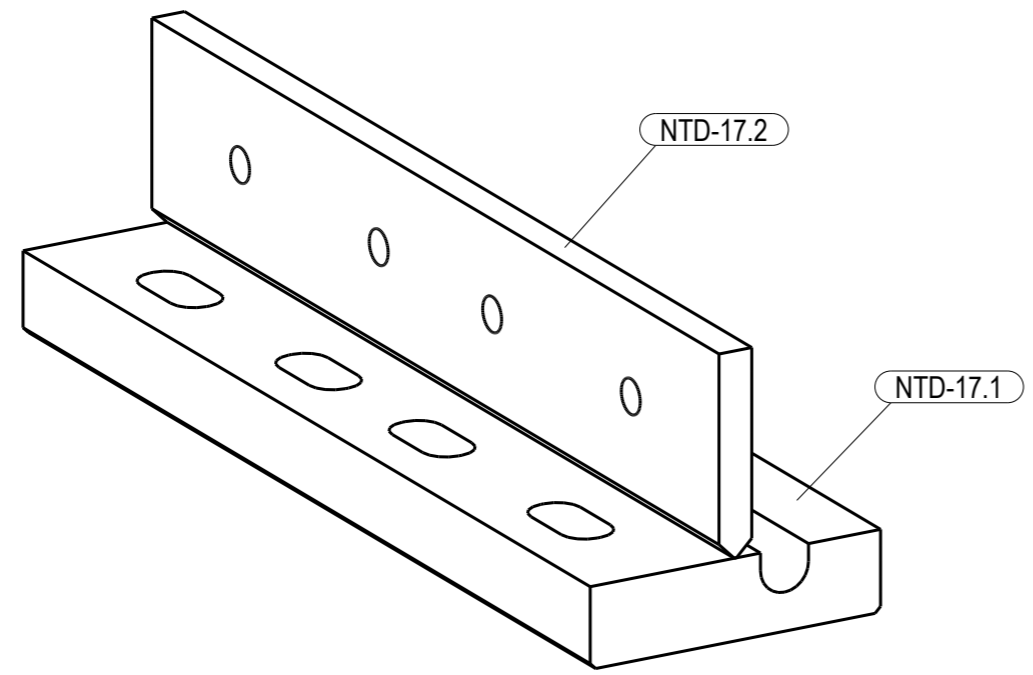
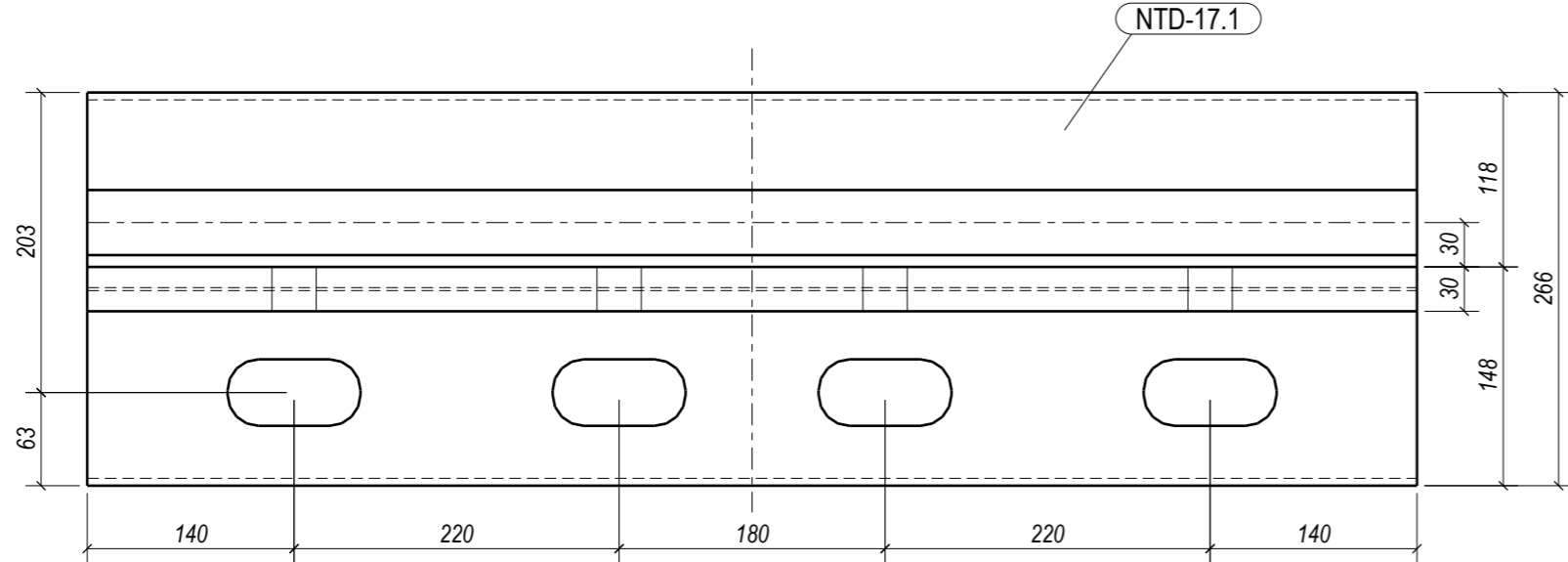
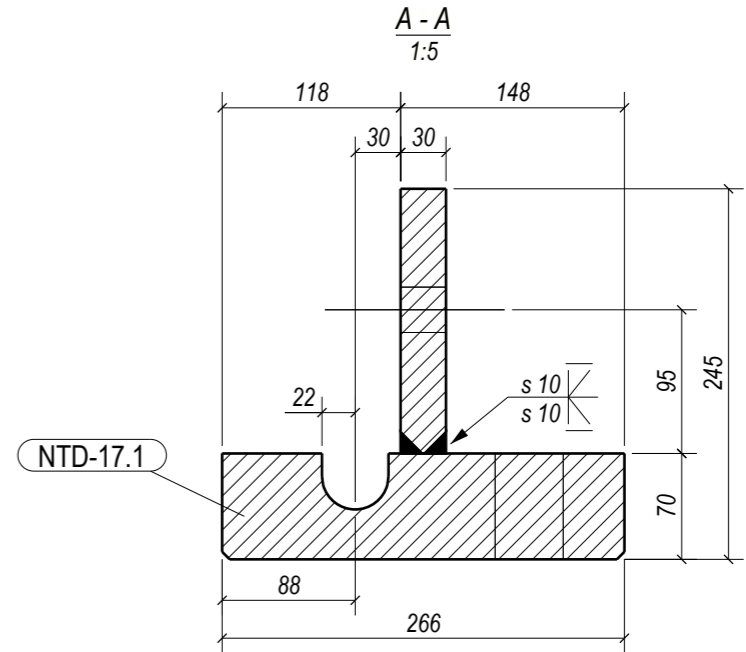
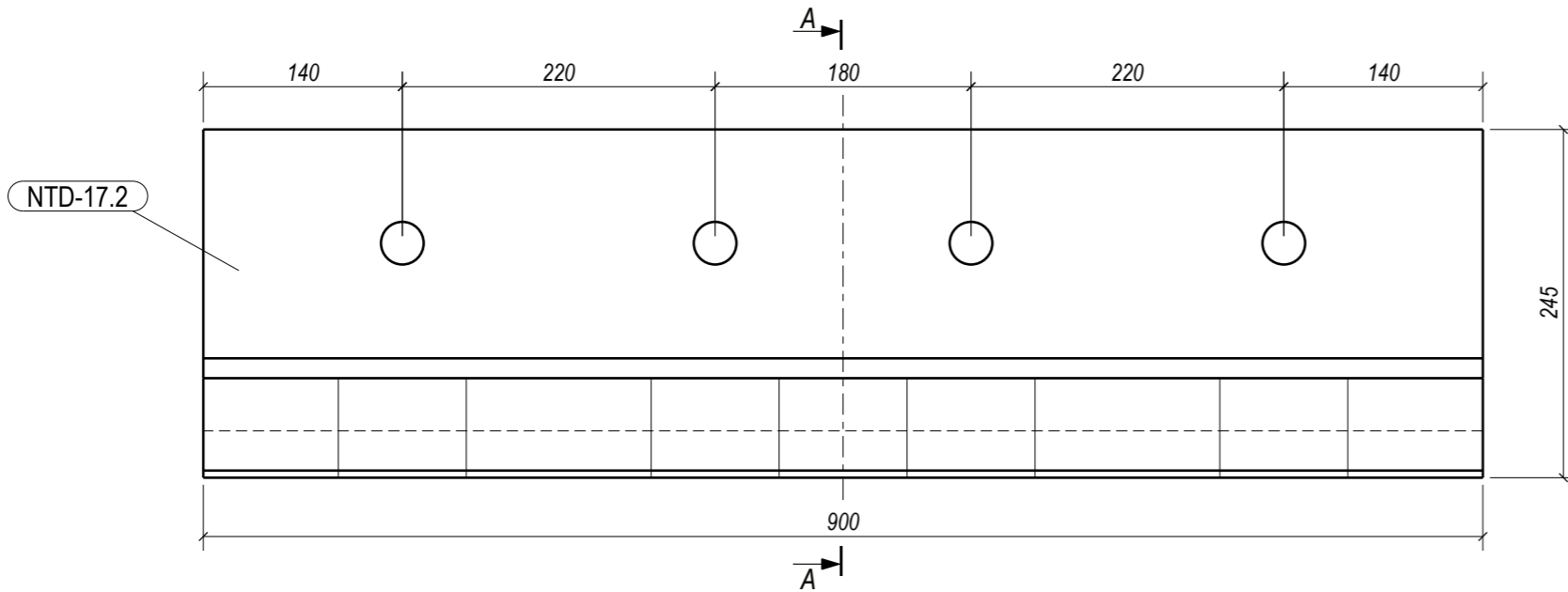

SPECIFICATION							
Part	Quantity	Profile	Length, mm	Weight, kg	Weight total, kg	Steel	Note
NTD-17.1	1	PL70*266	900	123.7	123.7	STAINLESS STEEL	
NTD-17.2	1	PL30*175	900	36.4	36.4	STAINLESS STEEL	
WELDS	1%				1.6		
TOTAL					161.7		
Object:						PRN - Nt17-1	
Customer:						161.7 kg	
Drawn					HINGE BASE		
Designed							
Checked							
Approved							
						Stage	MKD
						Page	Pages
						1	1